



FERRI srl - Via C.Govoni, 30 - 44030 Tamara (FE) Italy
Tel. +39-0532.866866 - Fax +39-0532.866851
<http://www.ferrisrl.it>
e-mail: ferrisrl@ferrisrl.it

TR

BARRA TRONCATRICE

CUTTER BAR

ASTSHNEIDER

SECATEUR

BARRA DE CORTE

CATALOGO DELLE PARTI DI RICAMBIO
SPARE PARTS CATALOGUE
ERSATZTEILKATALOG
CATALOGUE DE PIECES DETACHEES
CATALOGO DEL LAS PIEZAS DE RECAMBIO

TR13	Serien. Serial no. Seriennr. N. série Nùm. serie	01
------	--	----

TR22	Serien. Serial no. Seriennr. N. série Nùm. serie	01
------	--	----

**INDICE DELLE TAVOLE - INDEX OF PIECES - TABELLENINHALTSVIERZEICHNIS
INDEX DES PANNEAUX - INDICE DE LAS TABLAS**

TR13 - 01

TR22 - 01

C113

*Impianto idraulico servizi · Hydraulic installation to attachments ·
Hydraulikanlange für ausrüstungen · Installation hydraulique aux outils ·
Instalacion hidraulica equipos*

C247

*Impianto idraulico servizi · Hydraulic installation to attachments ·
Hydraulikanlange für ausrüstungen · Installation hydraulique aux outils ·
Instalacion hidraulica equipos*

D001

Martinetto · Jack · Zylinder · Vérin · Gato

F009

Telaio · Frame · Rahmen · Chassis · Bastidor

M068

Accessori · Options · Zubehoer · Options · Accesorios

M069

Accessori · Options · Zubehoer · Options · Accesorios

Z078

Collegamento · Connection · Verbindung · Accouplement · Enlace

TR13-TR22 → TXV50 VISION-TXV50 VISION ENERGY-TXV60 VISION-TXV60
VISION ENERGY

Z079

Collegamento · Connection · Verbindung · Accouplement · Enlace

TR13-TR22 → TP48 PARTNER FREE-TP60 PARTNER FREE

Z080

Collegamento · Connection · Verbindung · Accouplement · Enlace

TR13-TR22 → TGA50 PROFIT-TGA58Z PROFIT

Z081

Collegamento · Connection · Verbindung · Accouplement · Enlace

TR13-TR22 → TKZ70 TECHNOLOGY-TKZ80 TECHNOLOGY

Z082

Collegamento · Connection · Verbindung · Accouplement · Enlace

TR13-TR22 → TKZ70 TECHNOLOGY POWER-TKZ80 TECHNOLOGY POWER

INDICE FIGURATIVO - PICTURE INDEX - ABBILDUNGSVERZEICHNIS
INDEX FIGURATIF - INDICE FIGURATIVO

TR13 - 01

TR22 - 01

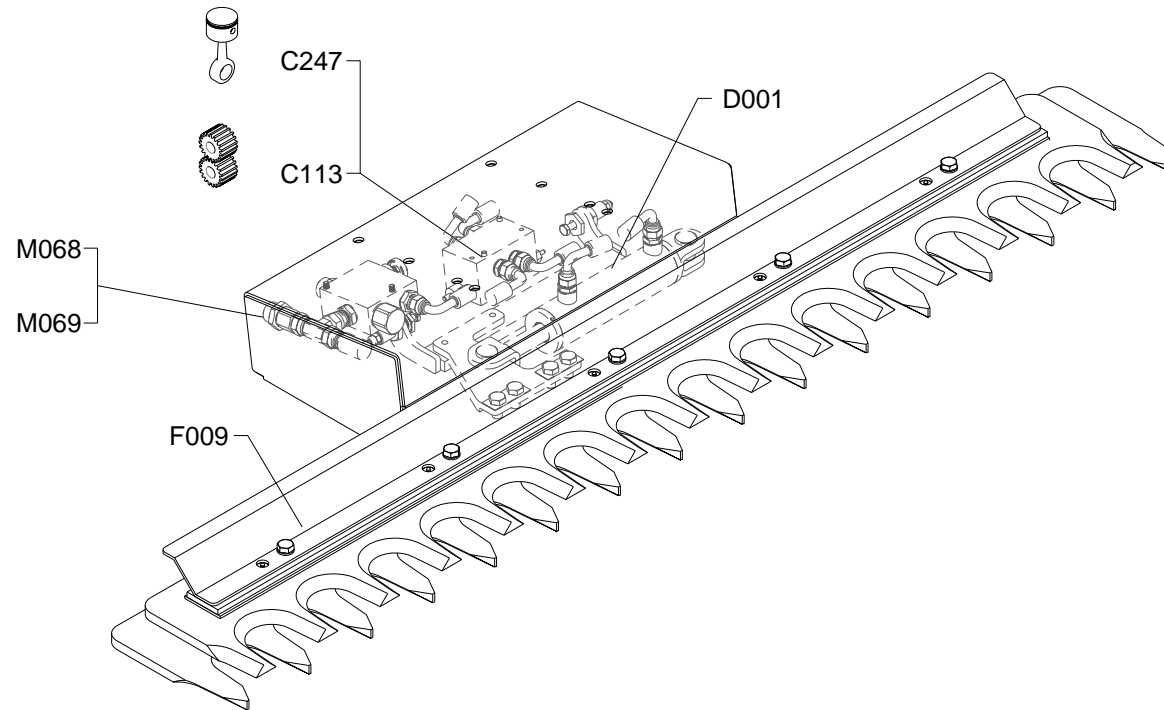
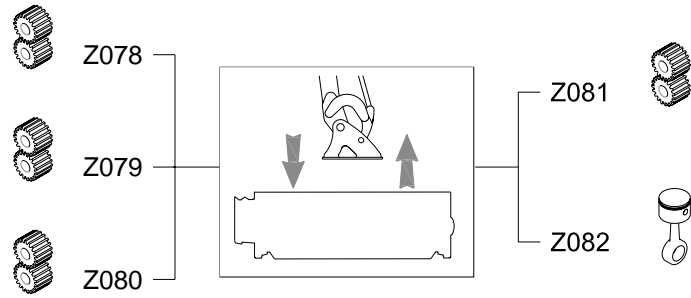

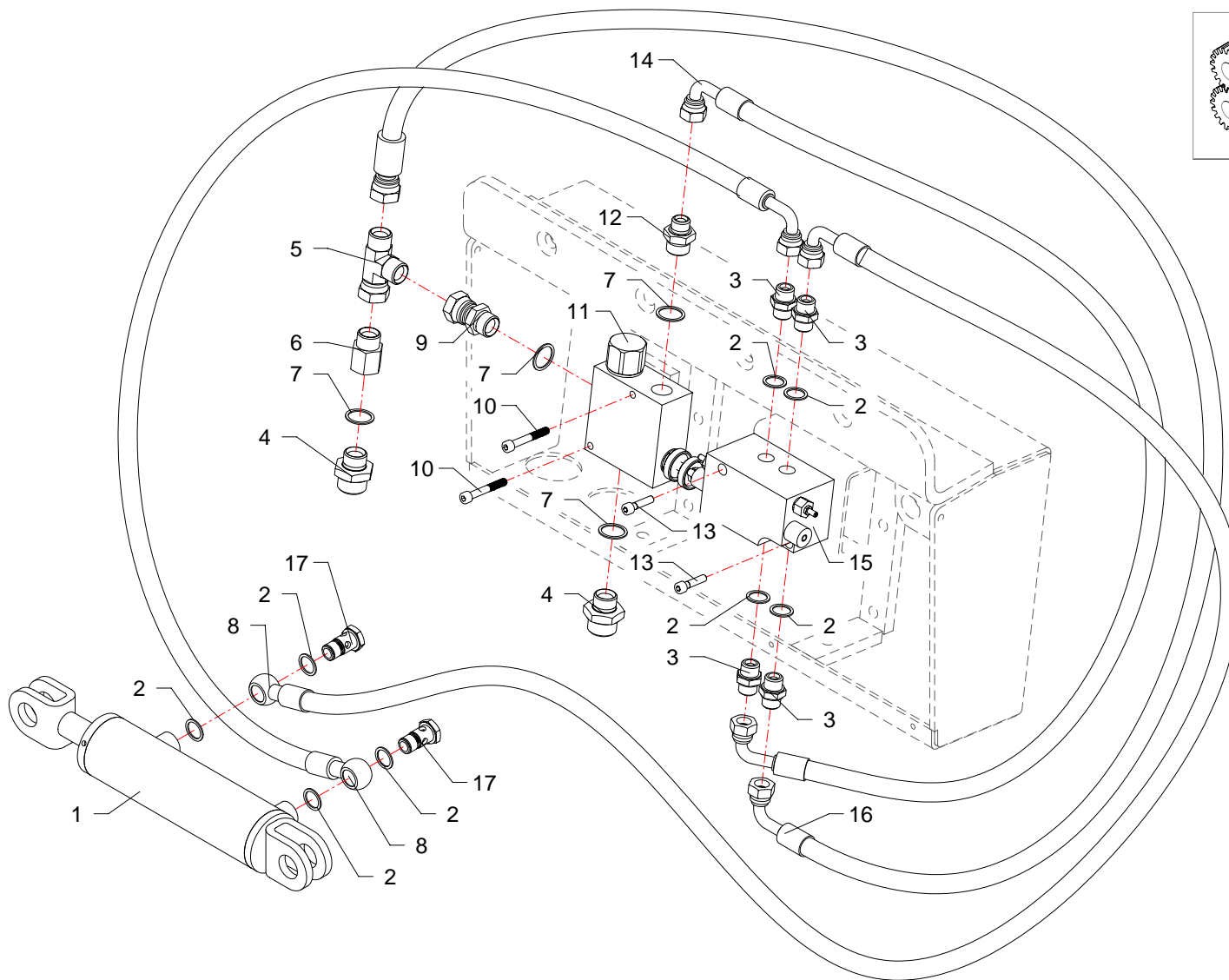
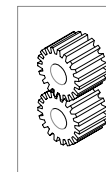

RIF	CODE	Qnt			Denominazione-Denomination-Bezeichnung-Denomination-Denominacion
		TR13 [01]	TR22 [01]		
1	27149000	1	1		Martinetto · Jack · Zylinder · Vérin · Gato
2	0408004	8	8		Rondella · Washer · Scheibe · Rondelle · Arandela
3	0402004	4	4		Nipplo · Nipple · Nippel · Niplo · Niple
4	0401009	2	2		Riduzione · Nipple · Nippel · Adapteur · Reduccion
5	0410032	1	1		Raccordo · Connector · Anschluss · Raccord · Brida
6	0426004	1	1		Prolunga · Extension · Verlaengerung · prolonge · Prolungacion
7	0408006	3	3		Rondella · Washer · Scheibe · Rondelle · Arandela
8	0503084	2	2		Tubo · Pipe · Schlauch · Tuyau · Tubo
9	0407005	1	1		Raccordo · Connector · Anschluss · Raccord · Brida
10	0317012Z	2	2		Vite · Bolt · Schraube · Vis · Tornillo
11	0417051	1	1		Valvola · Valve · Ventil · Soupape · Válvula
12	0401006	1	1		Riduzione · Nipple · Nippel · Adapteur · Reduccion
13	0317008Z	2	2		Vite · Bolt · Schraube · Vis · Tornillo
14	0503083	1	1		Tubo · Pipe · Schlauch · Tuyau · Tubo
15	0417060	1	1		Valvola · Valve · Ventil · Soupape · Válvula
16	0503082	1	1		Tubo · Pipe · Schlauch · Tuyau · Tubo
17	0412004	2	2		Vite cava · Hollow Screw · Hohlschraube · Vis creuse · Tornillo hueco

I GB D F E

Impianto idraulico servizi · Hydraulic installation to attachments · Hydraulikanlange fur ausrustungen · Installation hydraulique aux outils · Instalacion hidraulica equipos

FERRI

C113

FERRI

C247

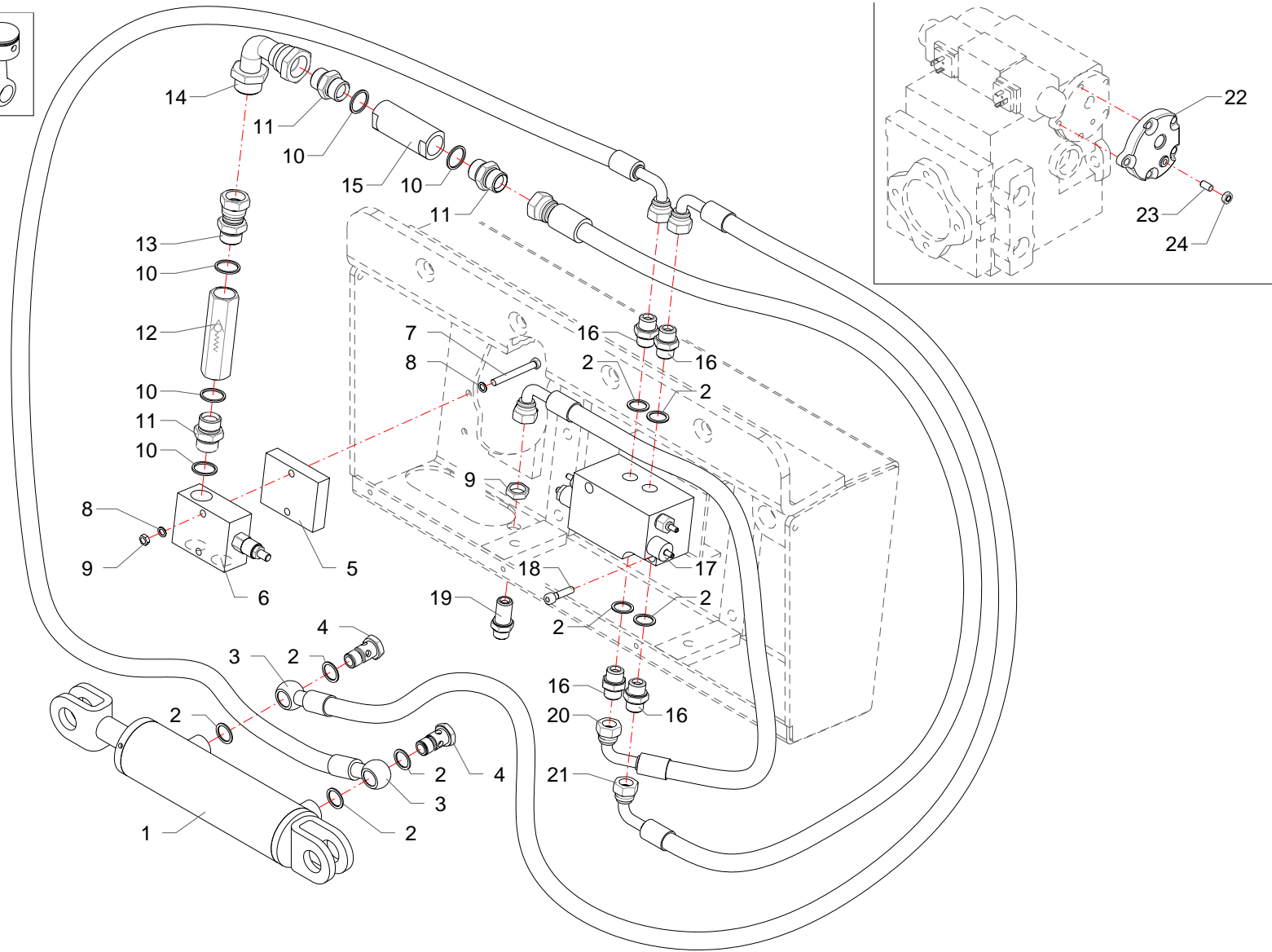
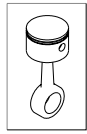

RIF	CODE	Qty				Denominazione-Denomination-Bezeichnung-Denomination-Denominacion
						
1	27149000	1	1			Martinetto · Jack · Zylinder · Vérin · Gato
2	0408004	8	8			Rondella · Washer · Scheibe · Rondelle · Arandela
3	0503084	2	2			Tubo · Pipe · Schlauch · Tuyau · Tubo
4	0412004	2	2			Vite cava · Hollow Screw · Hohlschraube · Vis creuse · Tornillo hueco
7	0301018	2	2			Vite · Bolt · Schraube · Vis · Tornillo
8	0321002Z	4	4			Rondella · Washer · Scheibe · Rondelle · Arandela
9	0359001	2	2			Dado · Nut · Mutter · Ecrou · Tuerca
10	0408006	5	5			Rondella · Washer · Scheibe · Rondelle · Arandela
11	0402006	3	3			Nipplo · Nipple · Nippel · Niplo · Niple
13	0407005	1	1			Raccordo · Connector · Anschluss · Raccord · Brida
14	0405006	1	1			Curva · Curve · Bogen · Manchon · Curva
16	0402004	4	4			Nipplo · Nipple · Nippel · Niplo · Niple
18	0317008Z	2	2			Vite · Bolt · Schraube · Vis · Tornillo
19	0425004	1	1			Passaparete · Fairlead · Durchgang · Passecloison · Guía pasapanel
21	0503082	1	1			Tubo · Pipe · Schlauch · Tuyau · Tubo
22	4410035	1	1			Coperchio · Cover · Deckel · Couvercle · Tapa
23	5000487	1	1			Grano · Dowel pin · Stift · Pivot de repere · Perno de centrado
24	612291	1	1			Dado · Nut · Mutter · Ecrou · Tuerca

Impianto idraulico servizi · Hydraulic installation to attachments · Hydraulikanlange für ausrüstungen · Installation hydraulique aux outils · Instalacion hidraulica equipos

FERRI

C247

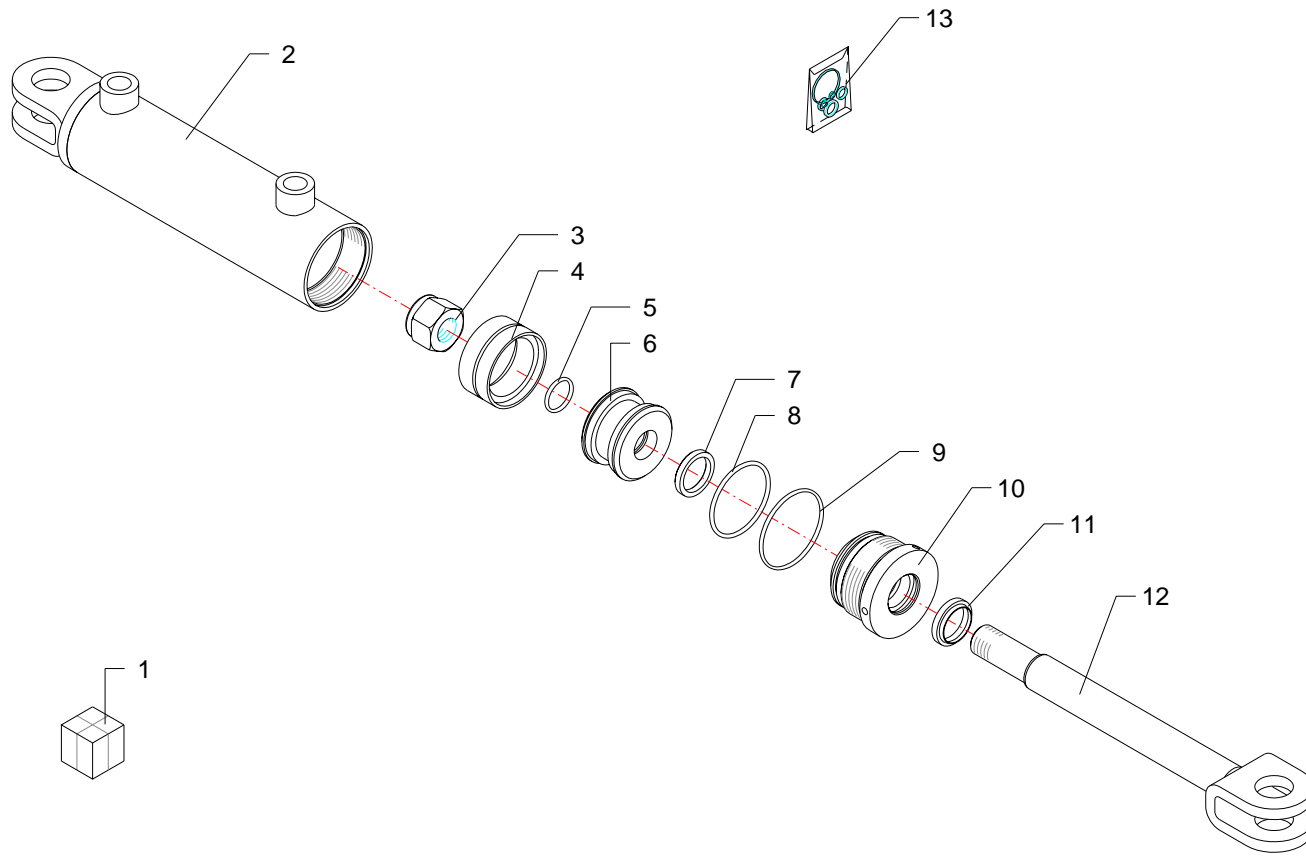

RIF	CODE	Qty				Denominazione-Denomination-Bezeichnung-Denomination-Denominacion
						I GB D F E
1	27149000	1				Martinetto · Jack · Zylinder · Vérin · Gato
2	27149010	1				Cilindro · Cylinder · Zylinder · Cylindre · Cilindro
3	0310009	1				Dado · Nut · Mutter · Ecrou · Tuerca
4	DBM255196	1				Guarnizione · Gasket · Dichtung · Joint · Empaquetadura
5	OR120	1				Guarnizione · Gasket · Dichtung · Joint · Empaquetadura
6	27127030	1				Pistone · Piston · Kolben · Piston · Piston
7	B149118	1				Guarnizione · Gasket · Dichtung · Joint · Empaquetadura
8	OR228	1				Guarnizione · Gasket · Dichtung · Joint · Empaquetadura
9	OR114	1				Guarnizione · Gasket · Dichtung · Joint · Empaquetadura
10	2703004	1				Ghiera · Locknut · Sicherungsring · Ecrou freine · Arandela
11	WRM118149	1				Guarnizione · Gasket · Dichtung · Joint · Empaquetadura
12	27149020	1				Stelo · Stem · Stange · Tige · Asta
13	2601002	1				Kit guarnizioni · Set of gaskets · Satzdichtungen · Jeu de joints · Serie de guarniciones

Martinetto · Jack · Zylinder · Vérin · Gato

FERRI

D001

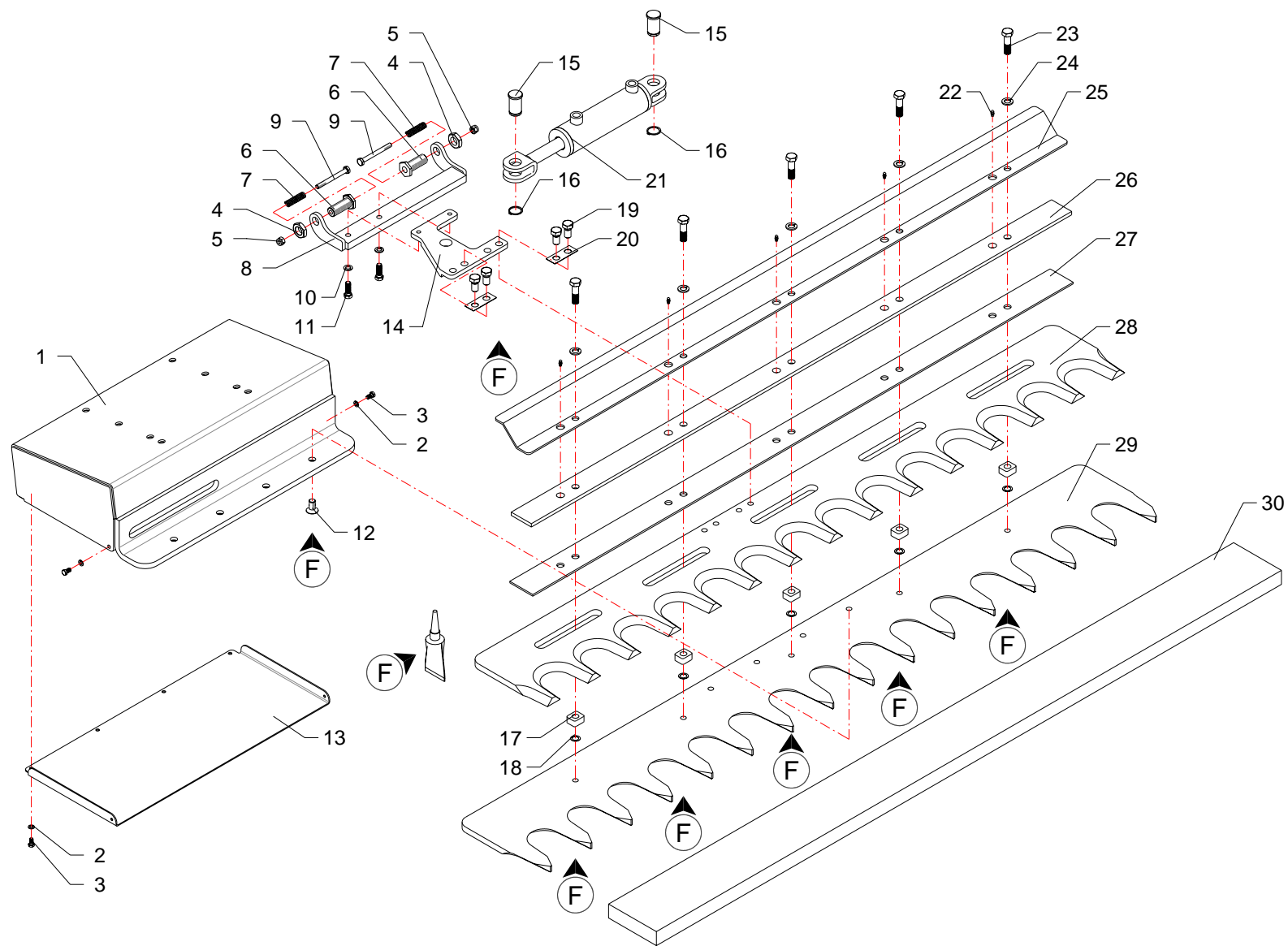

RIF	CODE	Qnt				Denominazione-Denomination-Bezeichnung-Denomination-Denominacion
		TR13 [01]	TR22 [01]			
1	TR22010100	1	1			Telaio · Frame · Rahmen · Chassis · Bastidor
2	0322002Z	4	4			Rondella · Washer · Scheibe · Rondelle · Arandela
3	0347005Z	4	4			Vite · Bolt · Schraube · Vis · Tornillo
4	0309019Z	2	2			Dado · Nut · Mutter · Ecrou · Tuerca
5	0310002	2	2			Dado · Nut · Mutter · Ecrou · Tuerca
6	TR22190100	2	2			Regolazione · Adjustment · Einstellung · Réglage · Regulación
7	2401033	2	2			Molla · Spring · Feder · Ressort · Muelle
8	TR22070300	1	1			Staffa · Clamp · Pratzte · Etrier · Brida
9	0302019Z	2	2			Vite · Bolt · Schraube · Vis · Tornillo
10	0322004Z	2	2			Rondella · Washer · Scheibe · Rondelle · Arandela
11	0343005Z	2	2			Vite · Bolt · Schraube · Vis · Tornillo
12	0314001Z	4	4			Vite · Bolt · Schraube · Vis · Tornillo
13	TR22170100	1	1			Coperchio · Cover · Deckel · Couvercle · Tapa
14	TR22070200	1	1			Staffa · Clamp · Pratzte · Etrier · Brida
15	TR22110100	2	2			Perno · Pin · Zapfen · Goujon · Perno
16	0324027	2	2			Seeger · Seeger · Seeger · Seeger · Seeger
17	TR22120100	3	5			Supporto · Bracket · Halterung · Support · Soporte
18	TR22140100	3	5			Rondella · Washer · Scheibe · Rondelle · Arandela
19	TR22190200	4	4			Vite · Bolt · Schraube · Vis · Tornillo
20	TR22150100	2	2			Fermo · Locking · Verschluss · Arret de securite · Parada
21	27149000	1	1			Martinetto · Jack · Zylinder · Vérin · Gato
22	0337001	3	5			Ingrassatore · Grease nipple · Schmiernippel · Graisseur · Engrasador
23	0304009Z	3	5			Vite · Bolt · Schraube · Vis · Tornillo
24	0322006Z	6	8			Rondella · Washer · Scheibe · Rondelle · Arandela
25	TR13120100	1				Supporto · Bracket · Halterung · Support · Soporte
25	TR22120200		1			Supporto · Bracket · Halterung · Support · Soporte
26	TR13160200	1				Piastra · Plate · Platte · Plate · Placa
26	TR22160200		1			Piastra · Plate · Platte · Plate · Placa
27	TR13160100	1				Pattino · Track shoe · Gleitstueck · Patin · Teja
27	TR22160100		1			Pattino · Track shoe · Gleitstueck · Patin · Teja
28	TR13300200	1				Lama · Knife · Klinge · Lame · Hoja
28	TR22300200		1			Lama · Knife · Klinge · Lame · Hoja
29	TR13300100	1				Lama · Knife · Klinge · Lame · Hoja
29	TR22300100		1			Lama · Knife · Klinge · Lame · Hoja
30	TR13170100	1				Protezione · Guard · Schutz · Protection · Proteccion

I GB D F E

Telaio · Frame · Rahmen · Chassis · Bastidor

FERRI

F009

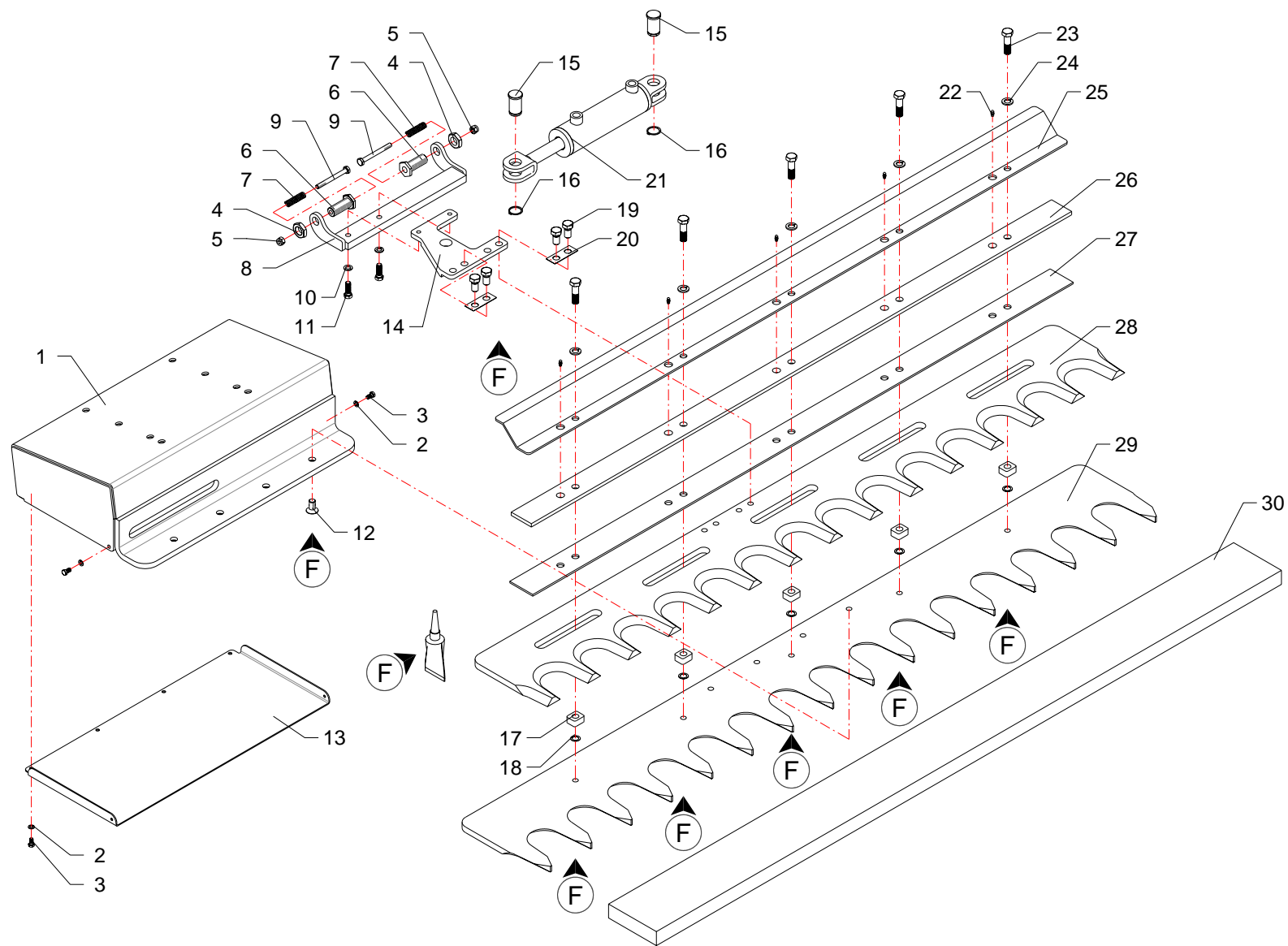

RIF	CODE	Qnt			Denominazione-Denomination-Bezeichnung-Denomination-Denominacion
		TR13 [01]	TR22 [01]		
30	TR22170200		1		Protezione · Guard · Schutz · Protection · Proteccion

I GB D F E

Telaio · Frame · Rahmen · Chassis · Bastidor

FERRI

F009

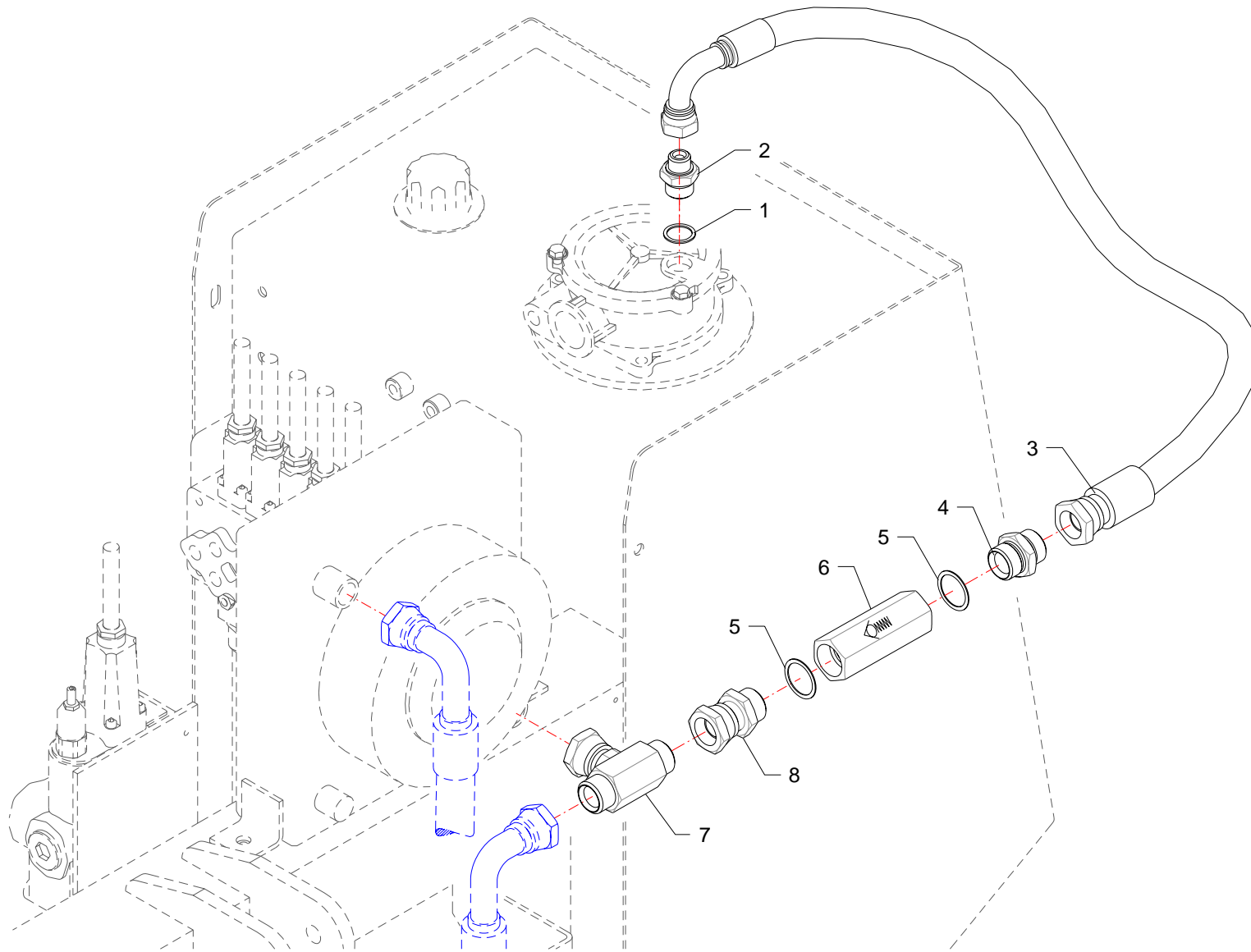

RIF	CODE	Qnt				Denominazione-Denomination-Bezeichnung-Denomination-Denominacion
		TR22 [01]				
						I GB D F E
1	0408004	1				Rondella · Washer · Scheibe · Rondelle · Arandela
2	0401006	1				Riduzione · Nipple · Nippel · Adapteur · Reduccion
3	0504125	1				Motore · Motor · Motor · Moteur · Motor
4	0402007	1				Nipplo · Nipple · Nippel · Niplo · Niple
5	0408007	1				Rondella · Washer · Scheibe · Rondelle · Arandela
6	0417082	1				Valvola · Valve · Ventil · Soupape · Vålvula
7	0410029	1				Raccordo · Connector · Anschluss · Raccord · Brida
8	0407006	1				Raccordo · Connector · Anschluss · Raccord · Brida

Accessori · Options · Zubehoer · Options · Accessorios

FERRI

M068

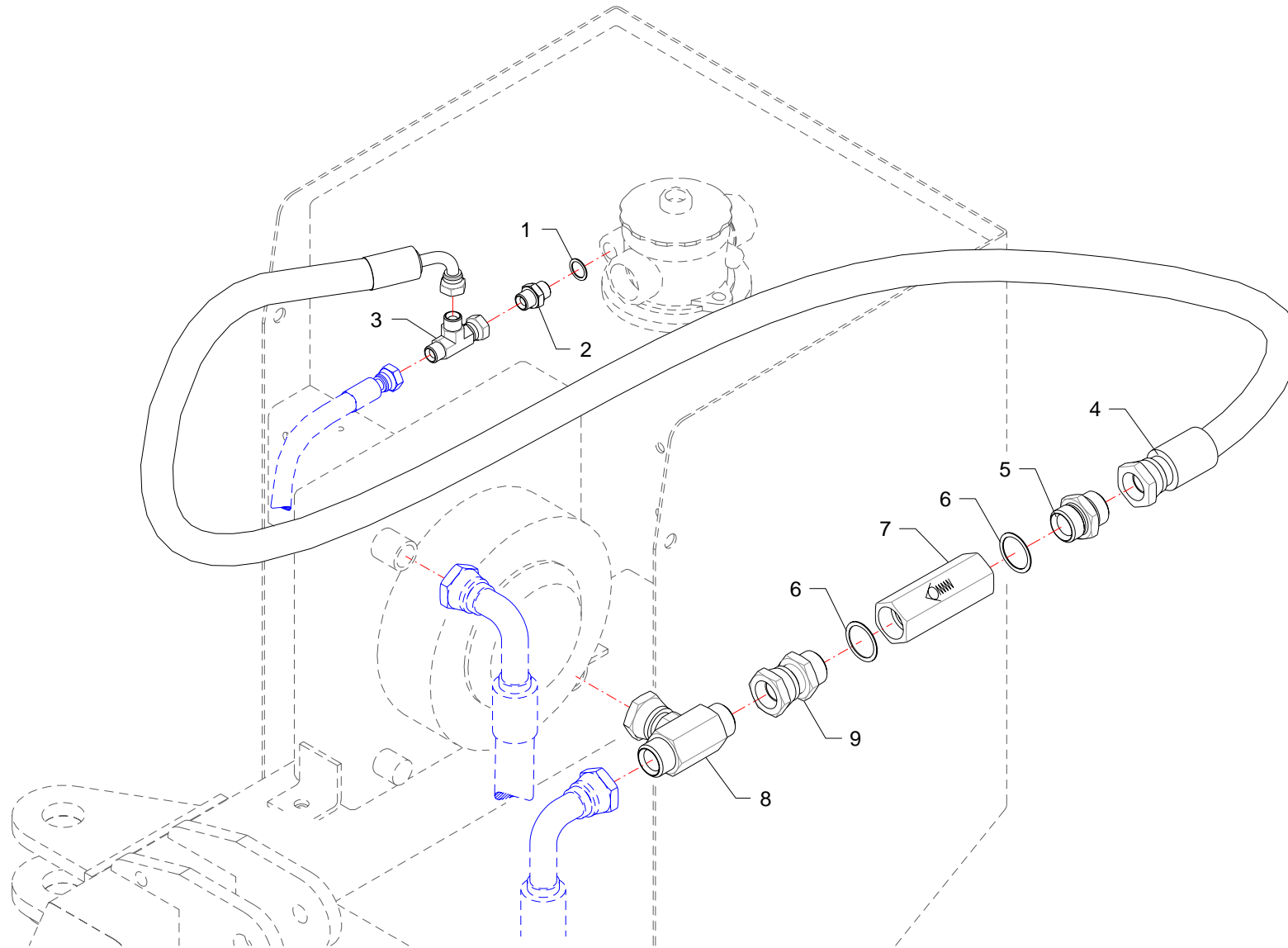

RIF	CODE	Qnt				Denominazione-Denomination-Bezeichnung-Denomination-Denominacion
		TR22 [01]				
1	0408003	1				Rondella · Washer · Scheibe · Rondelle · Arandela
2	0402003	1				Nipplo · Nipple · Nippel · Niplo · Niple
3	0410028	1				Raccordo · Connector · Anschluss · Raccord · Brida
4	0503110	1				Tubo · Pipe · Schlauch · Tuyau · Tubo
5	0401009	1				Riduzione · Nipple · Nippel · Adapteur · Reduccion
6	0408007	2				Rondella · Washer · Scheibe · Rondelle · Arandela
7	0417082	1				Valvola · Valve · Ventil · Soupape · Vlvula
8	0410029	1				Raccordo · Connector · Anschluss · Raccord · Brida
9	0407006	1				Raccordo · Connector · Anschluss · Raccord · Brida

I GB D F E

Accessori · Options · Zubehoer · Options · Accesorios

FERRI

M069

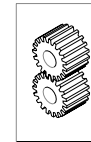
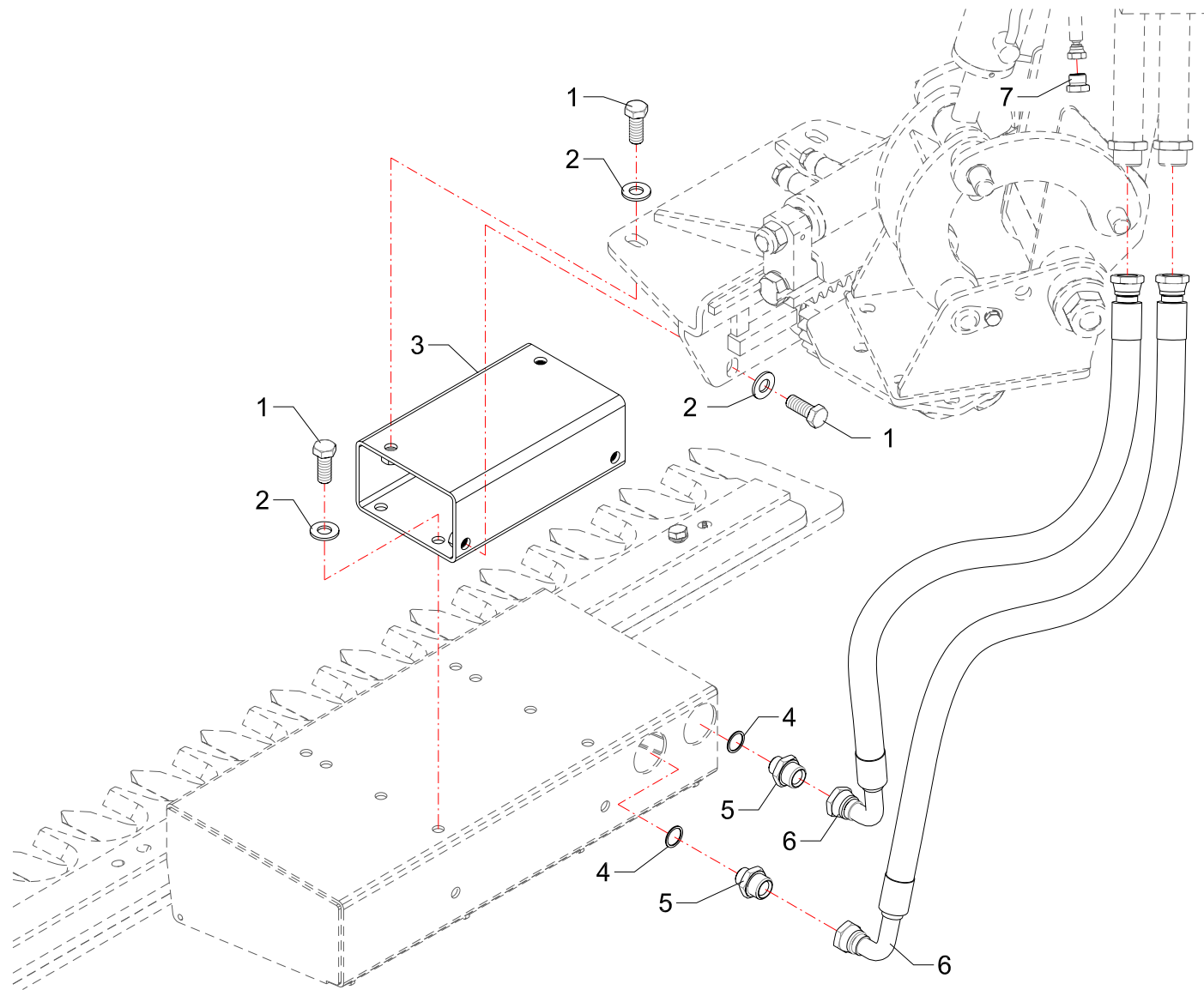

RIF	CODE	Qnt				Denominazione-Denomination-Bezeichnung-Denomination-Denominacion
						I GB D F E
1	0344005Z	8				Vite · Bolt · Schraube · Vis · Tornillo
2	0322006Z	8				Rondella · Washer · Scheibe · Rondelle · Arandela
3	TR22070400	1				Distanziale · Spacer · Distanzstueck · Entretoise · Separador
4	0408004	2				Rondella · Washer · Scheibe · Rondelle · Arandela
5	0402004	2				Nipplo · Nipple · Nippel · Niplo · Niple
6	0505049	2				Tubo · Pipe · Schlauch · Tuyau · Tubo
7	0418034	1				Tappo · Cap · Stopfen · Buchon · Tapon

Collegamento · Connection · Verbindung · Accouplement · Enlace

FERRI

TR13-TR22 → TXV50 VISION-TXV50 VISION ENERGY-TXV60 VISION-TXV60 VISION ENERGY

Z078

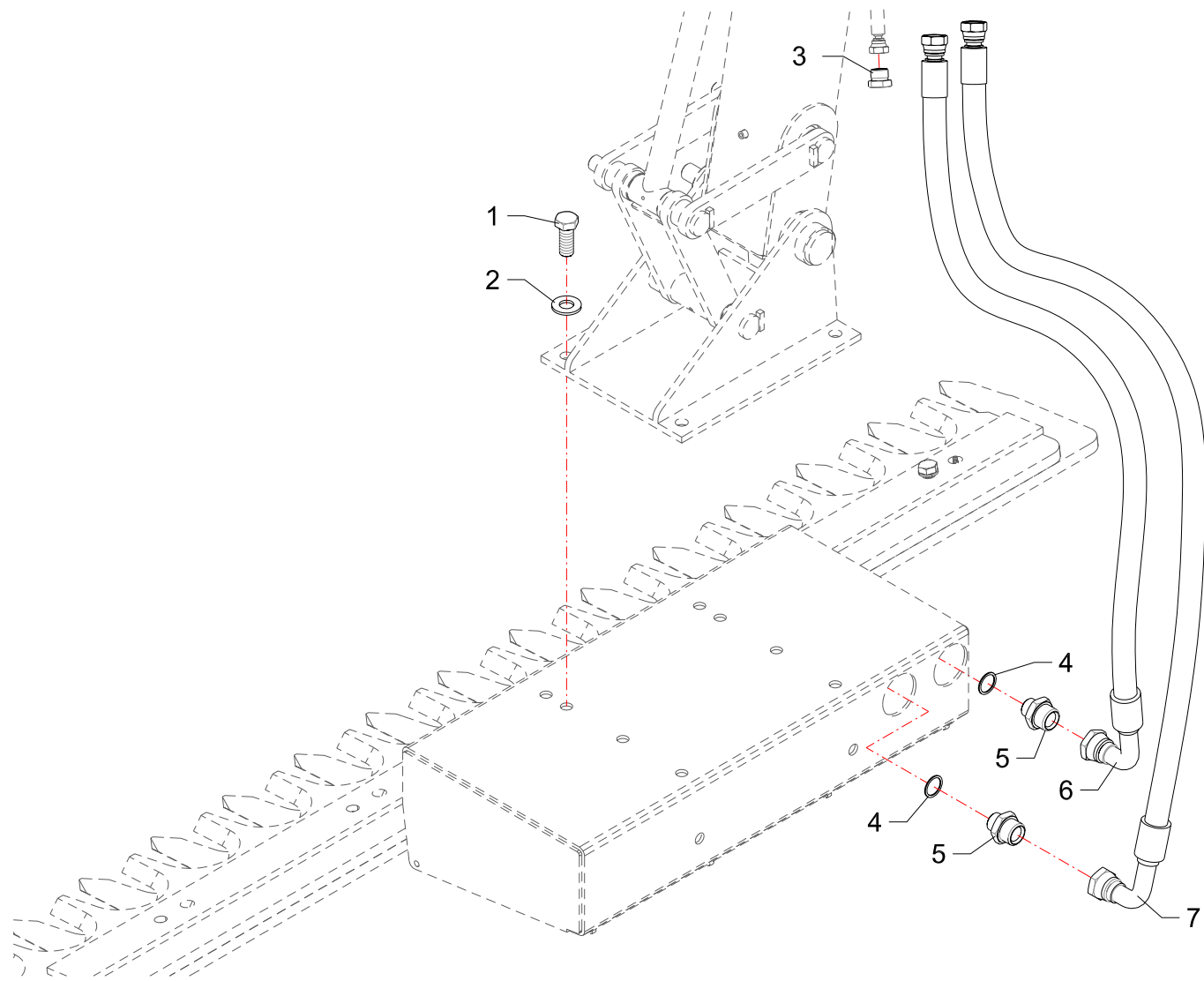

RIF	CODE	Qnt				Denominazione-Denomination-Bezeichnung-Denomination-Denominacion
						I GB D F E
1	0344005Z	8				Vite · Bolt · Schraube · Vis · Tornillo
2	0322006Z	8				Rondella · Washer · Scheibe · Rondelle · Arandela
3	0418034	1				Tappo · Cap · Stopfen · Buchon · Tapon
4	0408004	2				Rondella · Washer · Scheibe · Rondelle · Arandela
5	0402004	2				Nipplo · Nipple · Nippel · Niplo · Niple
6	0504079	1				Tube · Pipe · Schlauch · Tuyau · Tubo
7	0504080	1				Tube · Pipe · Schlauch · Tuyau · Tubo

Collegamento · Connection · Verbindung · Accouplement · Enlace

FERRI

TR13-TR22 → TP48 PARTNER FREE-TP60 PARTNER FREE

Z079

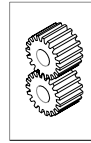
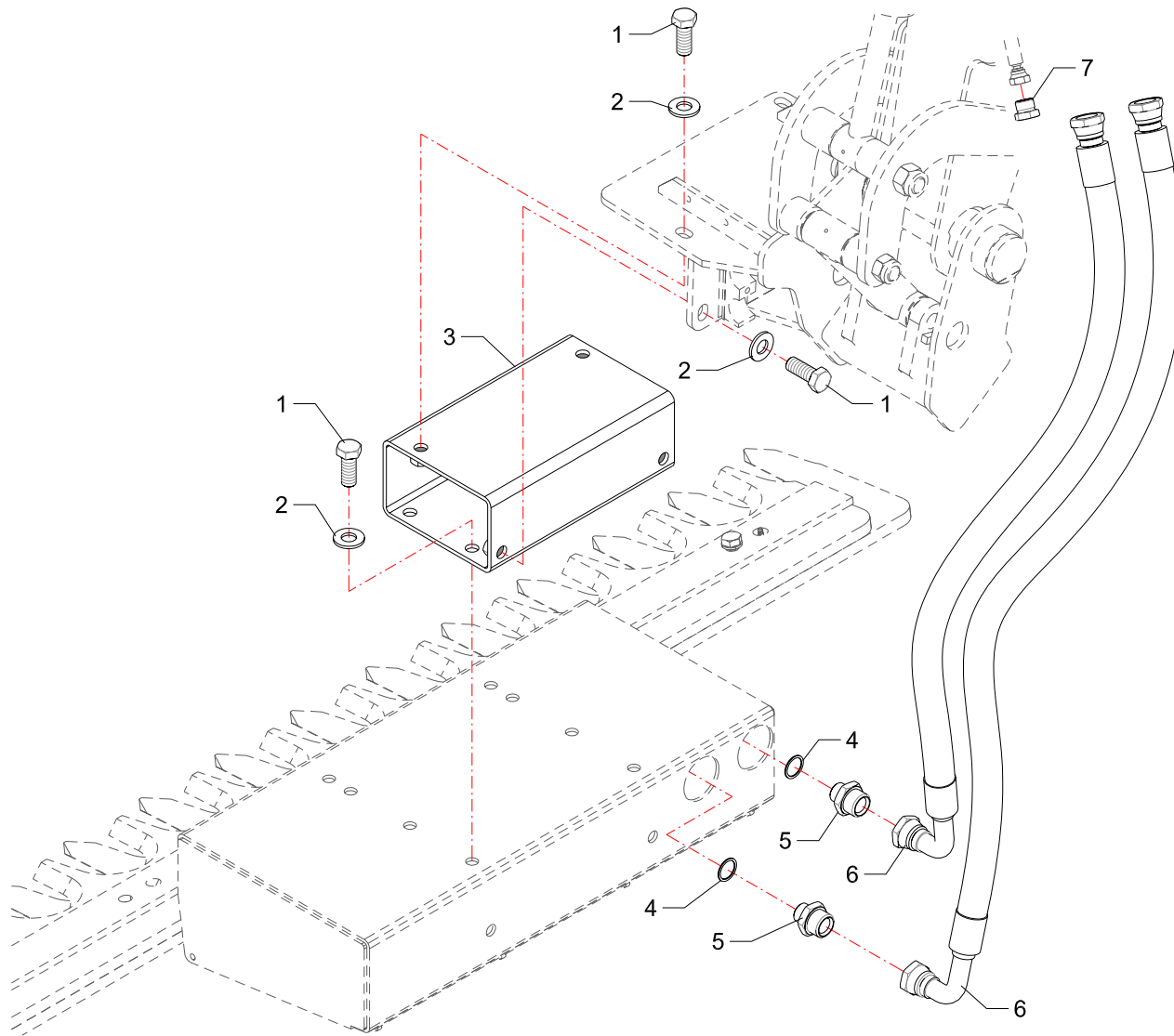

RIF	CODE	Qty				Denominazione-Denomination-Bezeichnung-Denomination-Denominacion
						I GB D F E
1	0344005Z	8				Vite · Bolt · Schraube · Vis · Tornillo
2	0322006Z	8				Rondella · Washer · Scheibe · Rondelle · Arandela
3	TR22070400	1				Distanziale · Spacer · Distanzstueck · Entretoise · Separador
4	0408004	2				Rondella · Washer · Scheibe · Rondelle · Arandela
5	0402004	2				Nipplo · Nipple · Nippel · Niplo · Niple
6	0505115	2				Tubo · Pipe · Schlauch · Tuyau · Tubo
7	0418034	1				Tappo · Cap · Stopfen · Buchon · Tapon

Collegamento · Connection · Verbindung · Accouplement · Enlace

FERRI

TR13-TR22 → TGA50 PROFIT-TGA58Z PROFIT

Z080

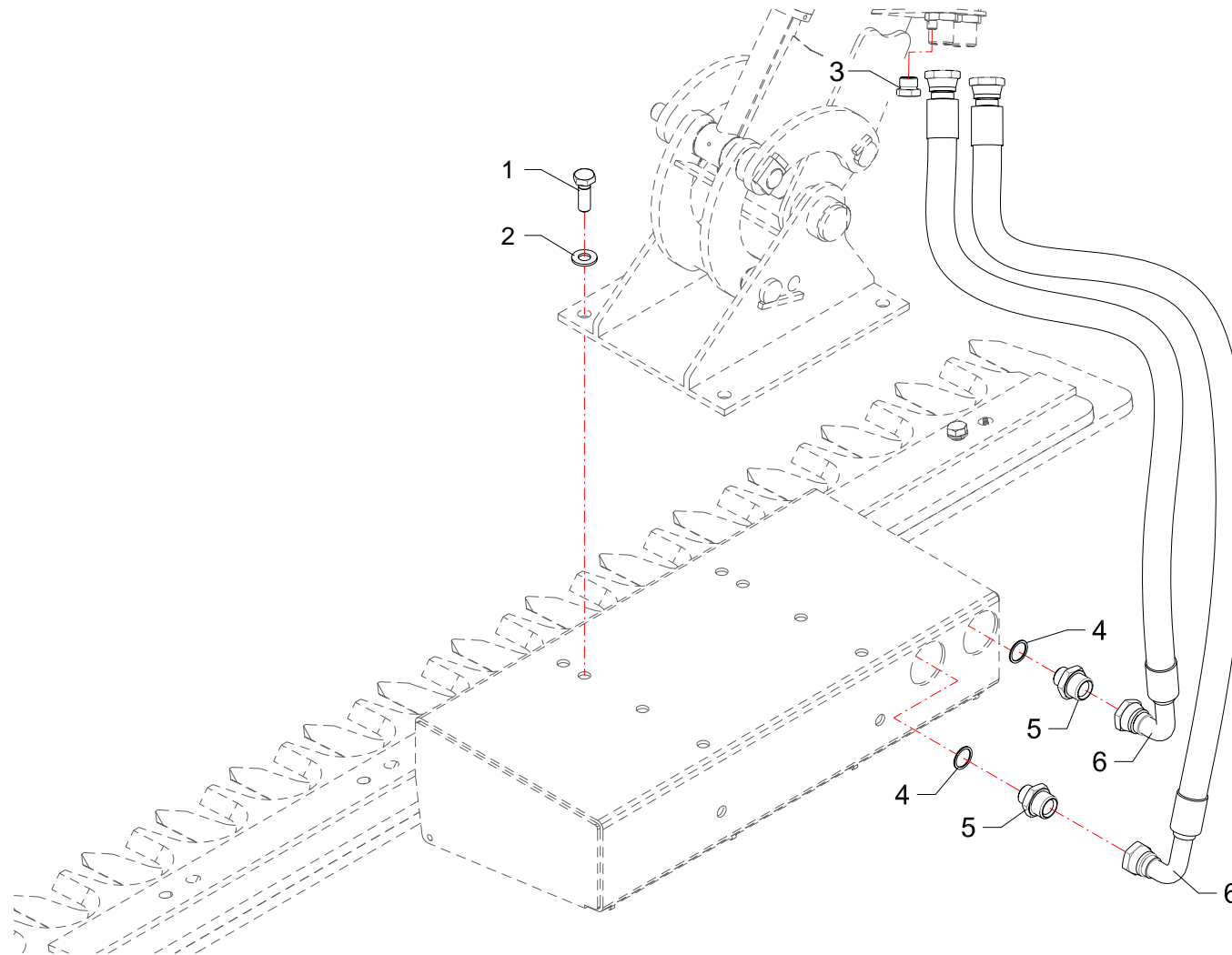
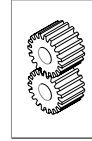

RIF	CODE	Qty				Denominazione-Denomination-Bezeichnung-Denomination-Denominacion
						
1	0344005Z	8				Vite · Bolt · Schraube · Vis · Tornillo
2	0322006Z	8				Rondella · Washer · Scheibe · Rondelle · Arandela
3	0418034	1				Tappo · Cap · Stopfen · Buchon · Tapon
4	0408004	2				Rondella · Washer · Scheibe · Rondelle · Arandela
5	0402004	2				Nipplo · Nipple · Nippel · Niplo · Niple
6	0505100	2				Tube · Pipe · Schlauch · Tuyau · Tubo

Collegamento · Connection · Verbindung · Accouplement · Enlace

FERRI

TR13-TR22 → TKZ70 TECHNOLOGY-TKZ80 TECHNOLOGY

Z081

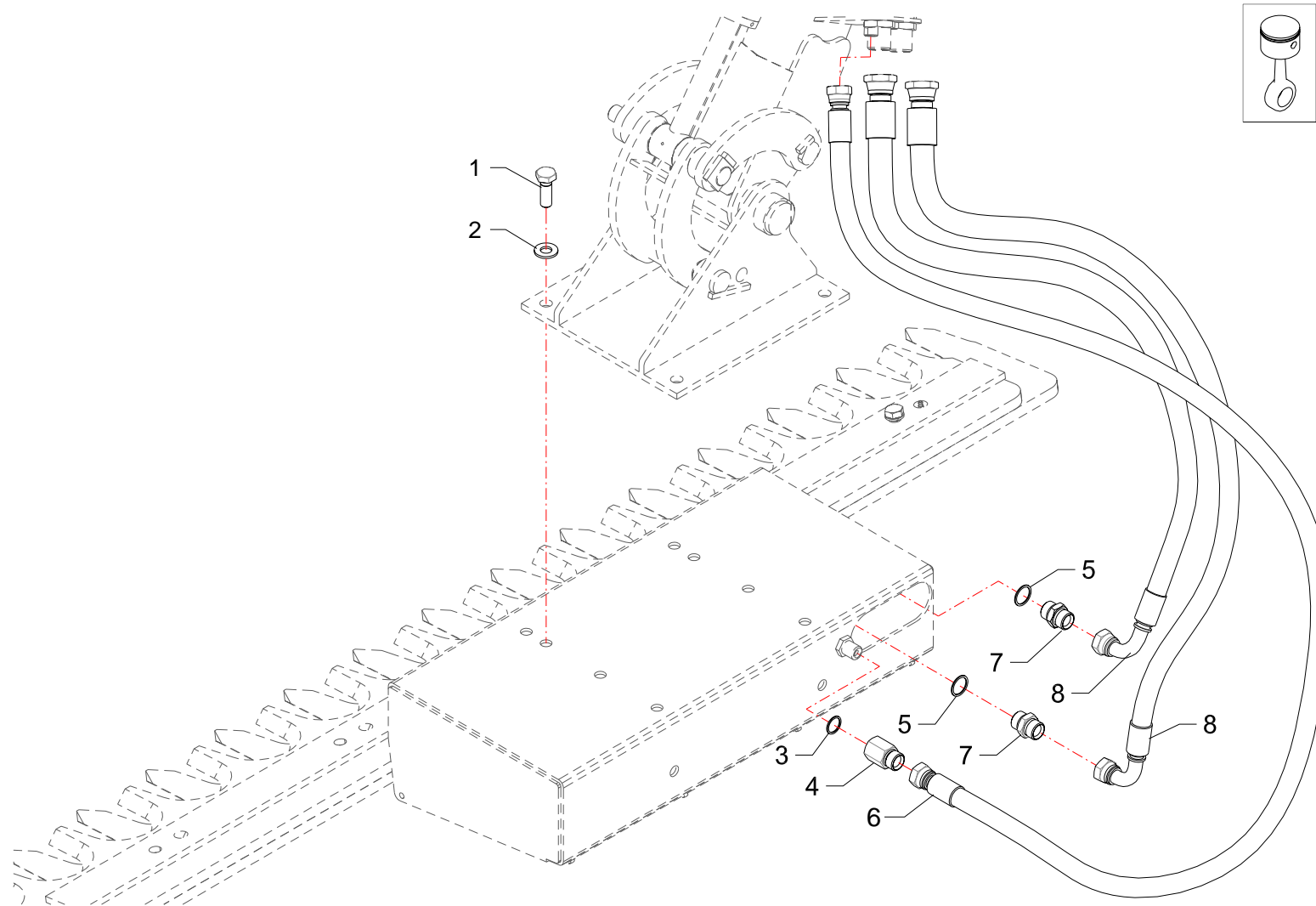

RIF	CODE	Qty				Denominazione-Denomination-Bezeichnung-Denomination-Denominacion
						I GB D F E
1	0344005Z	4				Vite · Bolt · Schraube · Vis · Tornillo
2	0322006Z	4				Rondella · Washer · Scheibe · Rondelle · Arandela
3	0408004	1				Rondella · Washer · Scheibe · Rondelle · Arandela
4	0421011	1				Riduzione · Nipple · Nippel · Adapteur · Reduccion
5	0408006	2				Rondella · Washer · Scheibe · Rondelle · Arandela
6	0504095	1				Tube · Pipe · Schlauch · Tuyau · Tubo
7	0402006	2				Nipplo · Nipple · Nippel · Niplo · Niple
8	0504094	2				Tube · Pipe · Schlauch · Tuyau · Tubo

Collegamento · Connection · Verbindung · Accouplement · Enlace

FERRI

TR13-TR22 → TKZ70 TECHNOLOGY POWER-TKZ80 TECHNOLOGY POWER

Z082

FERRI

Questa pagina è bianca per esigenza d'impostazione di catalogo

This page has been left blank for reasons of clarity

Diese weisse seite ist fur unsere katalogeintragungen bestimmt

On a laisse cette page en blanc pour de raisons de clarte

Se ha dejado en blanco esta pagina por razones de claridad

ELENCO ALFA-NUMERICO COMPONENTI TAVOLE CATALOGO

ALPHANUMERICAL PARTS LIST-EXPLODED-VIEW

ALPHANUMERISCHES TEILVERZEICHNIS-KATALOGTABELLEN

LISTA ALPHANUMERIQUE PIECES-TABLES CATALOGUE VUES ECLATEES

LISTA ALFANUMERICA PIEZAS-TABLAS CATALOGO PLANOS DESPEZADOS

CODE	Tavola	RIF	Qnt			
0301018	C247	7	2	2		
0302019Z	F009	9	2	2		
0304009Z	F009	23	3	5		
0309019Z	F009	4	2	2		
0310002	F009	5	2	2		
0310009	D001	3	1			
0314001Z	F009	12	4	4		
0317008Z	C113	13	2	2		
0317008Z	C247	18	2	2		
0317012Z	C113	10	2	2		
0321002Z	C247	8	4	4		
0322002Z	F009	2	4	4		
0322004Z	F009	10	2	2		
0322006Z	F009	24	6	8		
0322006Z	Z078	2	8			
0322006Z	Z079	2	8			
0322006Z	Z080	2	8			
0322006Z	Z081	2	8			
0322006Z	Z082	2	4			
0324027	F009	16	2	2		
0337001	F009	22	3	5		
0343005Z	F009	11	2	2		
0344005Z	Z078	1	8			
0344005Z	Z079	1	8			
0344005Z	Z080	1	8			
0344005Z	Z081	1	8			
0344005Z	Z082	1	4			
0347005Z	F009	3	4	4		
0359001	C247	9	2	2		
0401006	C113	12	1	1		
0401006	M068	2	1			
0401009	C113	4	2	2		
0401009	M069	5	1			
0402003	M069	2	1			
0402004	C113	3	4	4		
0402004	C247	16	4	4		
0402004	Z078	5	2			
0402004	Z079	5	2			

CODE	Tavola	RIF	Qnt			
0402004	Z080	5	2			
0402004	Z081	5	2			
0402006	C247	11	3	3		
0402006	Z082	7	2			
0402007	M068	4	1			
0405006	C247	14	1	1		
0407005	C113	9	1	1		
0407005	C247	13	1	1		
0407006	M068	8	1			
0407006	M069	9	1			
0408003	M069	1	1			
0408004	C113	2	8	8		
0408004	C247	2	8	8		
0408004	M068	1	1			
0408004	Z078	4	2			
0408004	Z079	4	2			
0408004	Z080	4	2			
0408004	Z081	4	2			
0408004	Z082	3	1			
0408006	C113	7	3	3		
0408006	C247	10	5	5		
0408006	Z082	5	2			
0408007	M068	5	1			
0408007	M069	6	2			
0410028	M069	3	1			
0410029	M068	7	1			
0410029	M069	8	1			
0410032	C113	5	1	1		
0412004	C113	17	2	2		
0412004	C247	4	2	2		
0417051	C113	11	1	1		
0417060	C113	15	1	1		
0417082	M068	6	1			
0417082	M069	7	1			
0418034	Z078	7	1			
0418034	Z079	3	1			
0418034	Z080	7	1			
0418034	Z081	3	1			

CODE	Tavola	RIF	Qnt			
0421011	Z082	4	1			
0425004	C247	19	1	1		
0426004	C113	6	1	1		
0503082	C113	16	1	1		
0503082	C247	21	1	1		
0503083	C113	14	1	1		
0503084	C113	8	2	2		
0503084	C247	3	2	2		
0503110	M069	4	1			
0504079	Z079	6	1			
0504080	Z079	7	1			
0504094	Z082	8	2			
0504095	Z082	6	1			
0504125	M068	3	1			
0505049	Z078	6	2			
0505100	Z081	6	2			
0505115	Z080	6	2			
2401033	F009	7	2	2		
2601002	D001	13	1			
2703004	D001	10	1			
27127030	D001	6	1			
27149000	C113	1	1	1		
27149000	C247	1	1	1		
27149000	D001	1	1			
27149000	F009	21	1	1		
27149010	D001	2	1			
27149020	D001	12	1			
4410035	C247	22	1	1		
5000487	C247	23	1	1		
612291	C247	24	1	1		
B149118	D001	7	1			
DBM255196	D001	4	1			
OR114	D001	9	1			
OR120	D001	5	1			
OR228	D001	8	1			
TR13120100	F009	25	1			
TR13160100	F009	27	1			
TR13160200	F009	26	1			



TR13 - 01

TR22 - 01

15/11/2004

CODE	Tavola	RIF	Qnt			
TR13170100	F009	30	1			
TR13300100	F009	29	1			
TR13300200	F009	28	1			
TR22010100	F009	1	1	1		
TR22070200	F009	14	1	1		
TR22070300	F009	8	1	1		
TR22070400	Z078	3	1			
TR22070400	Z080	3	1			
TR22110100	F009	15	2	2		
TR22120100	F009	17	3	5		
TR22120200	F009	25		1		
TR22140100	F009	18	3	5		
TR22150100	F009	20	2	2		
TR22160100	F009	27		1		
TR22160200	F009	26		1		
TR22170100	F009	13	1	1		
TR22170200	F009	30		1		
TR22190100	F009	6	2	2		
TR22190200	F009	19	4	4		
TR22300100	F009	29		1		
TR22300200	F009	28		1		
WRM118149	D001	11	1			

CODE	Tavola	RIF	Qnt
------	--------	-----	-----

CODE	Tavola	RIF	Qnt
------	--------	-----	-----

FERRI

TR13 - 01

TR22 - 01

15/11/2004

FERRI

Questa pagina è bianca per esigenza d'impostazione di catalogo

This page has been left blank for reasons of clarity

Diese weisse seite ist fur unsere katalogeintragungen bestimmt

On a laisse cette page en blanc pour de raisons de clarte

Se ha dejado en blanco esta pagina por razones de claridad